

FlowSol[®] B

RESOL[®]

Manual for the
specialized craftsman

Installation
Operation
Commissioning



11202306

Thank you for buying this RESOL product.
Please read this manual carefully to get the best performance from this unit.
Please keep this manual carefully.

en-US/CA

Manual

www.resol.com

Safety advice

Please pay attention to the following safety advice in order to avoid danger and damage to people and property.

Instructions

Attention should be paid to

- Valid national and local standards and regulations
- Respective valid standards and directives

Equipment to be installed and used in accordance with the rules of the National Electrical Code (NEC) or with Canadian Electrical Code (CEC), Part I.

These instructions are exclusively addressed to authorized skilled personnel.

- Only qualified electricians should carry out installation and maintenance work.
- Initial installation should be carried out by qualified personnel

Information about the product

Proper usage

The pump station may only be used in the solar circuit of solar thermal systems in compliance with the technical data specified in these instructions. Due to its design the station must be mounted and operated as described in these instructions!

Subject to technical change. Errors excepted.

Target group

These instructions are exclusively addressed to authorized skilled personnel.

Only qualified electricians should carry out electrical works.

Initial installation must be effected by qualified personnel named by the manufacturer.

Description of symbols

WARNING! Warnings are indicated with a warning triangle!



→ They contain information on how to avoid the danger described.

Signal words describe the danger that may occur, when it is not avoided.

- **WARNING** means that injury, possibly life-threatening injury, can occur.
- **ATTENTION** means that damage to the appliance can occur.



Note

Notes are indicated with an information symbol.

- Arrows indicate instruction steps that should be carried out.

Disposal

- Dispose of the packaging in an environmentally sound manner.
- Dispose of old appliances in an environmentally sound manner. Upon request we will take back your old appliances bought from us and guarantee an environmentally sound disposal of the devices.

Contents

1	Overview	3
2	Mounting the station.....	4
3	Flushing and filling the solar system.....	4
4	Ball valve positions	5
5	Draining the system	5
6	Non-return valves.....	5
7	Flowmeter.....	6
8	Air separator	6
9	Maintenance.....	6
10	Safety devices.....	6
11	Accessories	7
12	Information about the pump	7
13	Lists of spare parts	7

1 Overview

- Pre-assembled twin-line pump station
- Integrated controller of choice from the DeltaSol® BS or DeltaSol® BX series
- Safety assembly with connection for the diaphragm-type expansion vessel, safety valve and pressure gauge
- Fill and drain valves
- Wall mounting bracket and mounting material
- Design insulation
- Standard pump
- Ball valves in flow and return
- Air separator

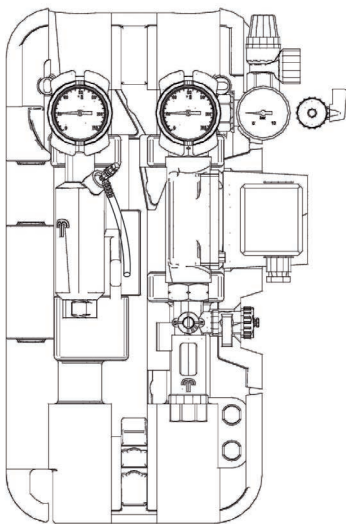

Technical data

Circulating pump: Wilo Star S16 U15 or Wilo Star S21 U15

Safety valve: 87 psi/6 bar

Pressure gauge: 0 ... 145 psi/0 ... 10 bar

Flowmeter: 0.25 ... 3.5 gpm/1 ... 13 l/min

Non-return valves:

Opening pressure 0.3 psi/20 mbar, openable

Connection to diaphragm-type expansion vessel: 3/4" IT NPT

Outlet safety valve: 3/4" IT NPT

Connections to the solar pipes: 3/4" IT NPT

Maximum temperature flow/return:

248 °F/203 °F

120 °C/95 °C

Maximum pressure: 87 psi/6 bar

Medium: Water with max. 50% glycol

Dimensions:

Approx. 18.94" × 12.6" × 7.48" / 481 × 320 × 190 mm (with insulation)

Distance centres: approx. 3.94"/100 mm

Distance centre/wall: approx. 2.64"/67 mm

Material:

Fittings: brass

Seals: AFM 34

Insulation: EPP foam

Pump characteristic/pressure loss characteristic

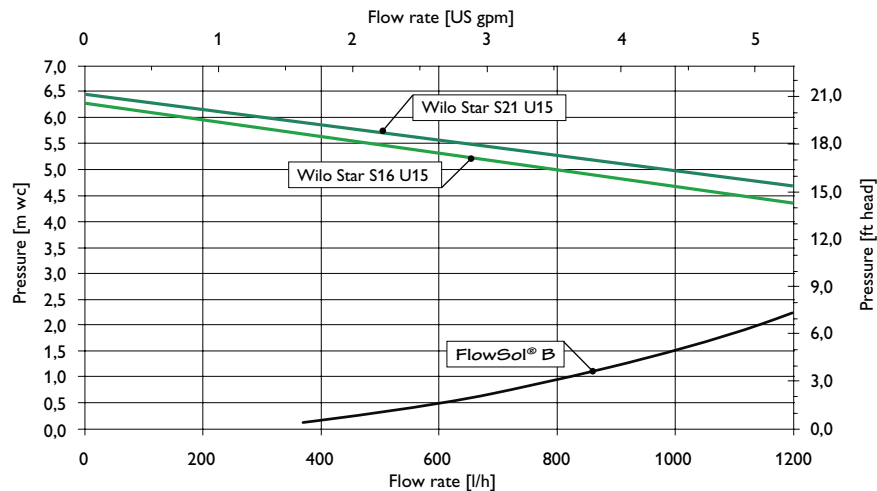

2 Mounting the station

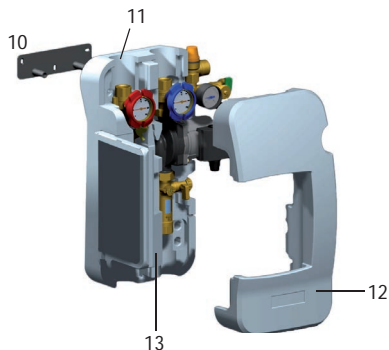

- 10 Wall mounting bracket
- 11 Back half of the insulation
- 12 Front half of the insulation
- 13 Hinged controller panel

Controller and controller panel depend on the version of the station

- ➔ Determine the mounting site of the station.
- ➔ Mark the drill holes by means of the template enclosed, then drill and insert wall plugs (see figure to the right).
- ➔ Take the station out of the packaging.
- ➔ Remove the front half of the insulation. Leave the pump station attached to the back half of the insulation!
- ➔ Fasten the pump station to the wall with the enclosed screws. For this purpose, use a crosshead screw driver.
- ➔ Fold the hinged controller panel to the left.
- ➔ Connect the pipework from the tank and the collector respectively to the pump station.



Note

All connections are already tightened such that they usually do not have to be tightened again. However, during commissioning of the system all connections have to be checked for leaks (pressure test).

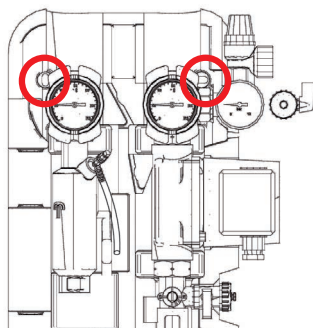

3 Flushing and filling the solar system

WARNING!



Scald danger! Pressure surge damage!

If the medium enters strongly heated, empty collectors, pressure surges caused by evaporation can occur.

- ➔ **In order to prevent the solar fluid from vaporizing inside the collectors, do not fill or flush the system during times of strong irradiation!**

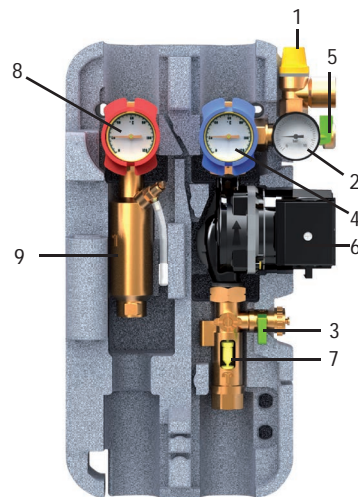

- 1 Safety valve
- 2 Pressure gauge
- 3 Drain valve
- 4 Ball valve (return) with thermometer and integrated non-return valve
- 5 Fill valve
- 6 Pump
- 7 Flowmeter
- 8 Ball valve (flow) with thermometer and integrated non-return valve
- 9 Air separator

Before flushing the system

- Disconnect the expansion vessel from the solar thermal system.

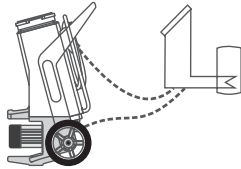

- Connect the pressure hose of the filling and flushing station to the fill valve (5) of the pump station.
- Connect the flushing hose of the filling and flushing station to the drain valve (3) of the pump station.

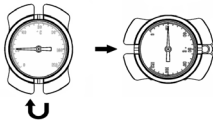

- Close the ball valve of the pump station (4).
- Open the fill valve (5) and the drain valve (3).
- Switch on the filling pump of the filling and flushing station.
- Flush the solar thermal system for at least 15 minutes by means of the filling and flushing station until the discharged solar fluid is free of gas bubbles and dirt particles.
- During flushing, bleed the solar thermal system several times until the discharged solar fluid (e.g. Tyfocor®, see chap. 11) is free of air bubbles.
- Open the ball valve of the pump station (4).

After flushing the system

- Connect the expansion vessel to the solar thermal system
- Close the drain valve (3) of the pump station while the filling pump is running.



- Increase system pressure (approx. 51... 58 psi/ 3.5... 4 bar). The system pressure can be read from the pressure gauge.
- Close the fill valve (5).
- Switch off the filling pump.
- Check the pressure gauge to see whether the system pressure reduces and eliminate leaks where necessary.
- Slowly discharge the heat transfer fluid by means of the drain valve (3) until the operating pressure is set.
- Remove the hoses of the filling and flushing station and screw the caps onto the fill and drain valves. Manually start the solar thermal pump at maximum speed (see controller manual) and let the fluid circulate for at least 15 minutes.
- Bleed the solar thermal system several times.
- Check the system pressure at the pressure gauge.



- Check the antifreeze ratio (not required if a ready-mix is used).

4 Ball valve positions



Non-return valve in operating position, fluid flow in flow direction only



Ball valve open, fluid flow in both directions possible



Ball valve closed, no fluid flow

5 Draining the system

- Open the ball valve (4).
- Open the air vent at the highest point of the system (above the collectors).
- Open the drain valve.

6 Non-return valves

The non-return valves of the pump station are integrated into the ball valves in flow and return and have an opening pressure of 0.3 psi/ 20 mbar.

In order to completely drain the system, the non-return valves have to be opened.

- For this purpose, turn the handles of the ball valves by 45°.
- For normal system operation, open the ball valves completely.

7 Flowmeter

The flowmeter measures and indicates the flow rate with a range of 0.25... 3.5 gpm / 1... 13 l/min. For the device to function faultlessly, the system must be flushed and free of grit.

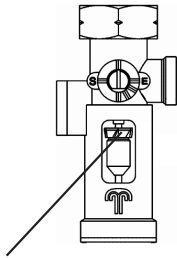

Read the flow rate from the upper edge of the float

8 Air separator

WARNING!

Scald danger!

During venting, the air discharged can reach temperatures of more than 212 °F / 100 °C.

→ In order to avoid scalding, pay attention to the system temperatures!



The air separator is used for venting the water / glycol mixture in the solar circuit. The air separated from the heat transfer fluid gathers in the air scoop and can be discharged manually at the air vent valve.

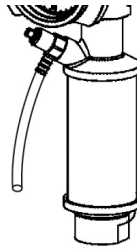

- Open the air vent valve and collect the discharged fluid in a suitable container.
- Check the system pressure after bleeding and, if necessary, increase it to the specified operating pressure.

9 Maintenance

In the case of maintenance (such as a replacement of the pump) proceed as follows:

- Close the ball valve (4).
- Turn the slot of the flowmeter spindle by 90° anti-clockwise (see figure below).

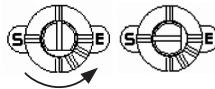

The heat transfer fluid can now be drained from the pump.

- Open the drain valve (3).
- If necessary, open the union nut at the pressure side.
- Now dismount the pump.

10 Safety devices

The pump station is equipped with a diaphragm safety valve which corresponds to the relevant directives and regulations. For installation and operation, please pay attention to the following advice:

- The safety valve has to be easily accessible. The efficiency of the valve must not be influenced or disabled by barriers!
- The strainer or other restriction devices must not be mounted between collector (-field) and safety valve!
- The diameter of the discharge pipe must correspond to the diameter of the valve outlet; the maximum length must not exceed 6.6 ft / 2 m; more than 2 bends are inadmissible. When these values are exceeded, you have to install a discharge pipe with larger dimensions. Do not use more than 3 bends and pipes longer than 13.1 ft / 4 m!
- If the discharge pipe leads into a drain pipe with a funnel, the diameter of the drain pipe has to be at least twice as large as the valve inlet. The opening of the discharge pipe must be inclined downwards. It must be routed such that the opening can be seen but does not present any risk to a person standing or passing by.
- We recommend placing a container below the discharge pipe. If the safety valve opens, the fluid will be collected and can be refilled into the system when the pressure is too low.

11 Accessories



SBS 2000 filling and flushing station

The SBS 2000 has been especially designed for professionally filling and flushing solar thermal and heating systems. Its many thought-out details facilitate transport, operation and cleaning, the attractive design makes it the ideal companion for a professional performance.

Article no: **280 010 97**

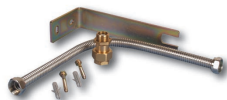

Wall mounting for diaphragm-type expansion vessel

Wall mounting for diaphragm-type expansion vessel with screws and wall plugs, high grade steel corrugated tube and connection thread $\frac{3}{4}$ ". Including quick release valve coupling enabling removal of expansion without draining down of the system.

Article no: **280 004 60**



Heat transfer and cleaning fluids

In our product portfolio, you will find a range of heat transfer fluids for different applications, available as ready-mix or concentrate, as well as cleaning fluids.



Filling and injection pump

Filling and injection pump with non-return valve for pressure increase and refilling of heat transfer fluids. $\frac{1}{2}$ " OT self-sealing with O-ring, 0.6"/15 mm tube connection. Pump output 0.5 gmp/2l/min, 64 psi/4.5 bar max.

Article no: **280 005 40**



ALS15 discharge hose

4 ft/1.5 m hose for connection to the safety valve of the FlowSol® B pump station.

Article no: **280 004 92**

See our full range of accessories on our website:
www.resol.com

12 Information about the pump

Depending on the version, the station is equipped with different pumps. Data concerning the pump in your station are available at the pump manufacturer under www.wilointec.com. Upon request we will provide you with further information.

13 Lists of spare parts

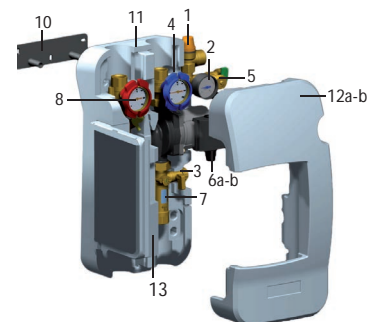

Pos.	Art. no.	Article
1	11200054	Safety valve 87 psi/6 bar
1a	11202311	Safety valve adapter NPT
2	11202319	Pressure gauge
3	11200058	Fill/Drain valve
4	11202312	Ball valve (return) with thermometer and integrated non-return valve
5	11200058	Fill/Drain valve
5a	11202313	Fill/Drain valve adapter GHT
6a	28001501	Pump WILO S16U/15
6b	or 28001502	Pump WILO S21U/15
7	11202320	Flowmeter
8	11202321	Ball valve (flow) with thermometer and integrated non-return valve
9	11202322	Air separator (not shown)
10	11200071	Wall mounting bracket
11	70001512	Back half of the insulation
12a	70001614	Front half of the insulation DeltaSol® BX
12b	or 70001613	Front half of the insulation DeltaSol® B/C (not shown)
13	70001612	Hinged controller panel

Distributed by:

RESOL – Elektronische Regelungen GmbH

Heiskampstraße 10

45527 Hattingen / Germany

Tel.: +49 (0) 23 24 / 96 48 - 0

Fax: +49 (0) 23 24 / 96 48 - 755

www.resol.com

info@resol.com

Important note

The texts and drawings in this manual are correct to the best of our knowledge. As faults can never be excluded, please note:

Your own calculations and plans, under consideration of the current standards and directions should only be basis for your projects. We do not offer a guarantee for the completeness of the drawings and texts of this manual - they only represent some examples. They can only be used at your own risk. No liability is assumed for incorrect, incomplete or false information and / or the resulting damages.

Note

The design and the specifications can be changed without notice. The illustrations may differ from the original product.

Imprint

This manual including all parts is copyrighted. Another use outside the copyright requires the approval of RESOL – Elektronische Regelungen GmbH. This especially applies for copies, translations, micro films and the storage into electronic systems.

Editor: RESOL – Elektronische Regelungen GmbH